

OPERATIONAL PLAN

Sioux Lookout Drinking Water System

Hudson Drinking Water System

Revision 7

Table of Contents

DWQMS Matrix	3
1 Quality Management System	5
2 Quality Management System Policy	5
3 Commitment and Endorsement.....	5
4 QMS Representative.....	6
5 Document & Records Control.....	6
6 Drinking-Water System	6
7 Risk Assessment	19
8 Risk Assessment Outcomes	19
9 Organizational Structure, Roles, Responsibilities and Authorities	20
10 Competencies.....	20
11 Personnel Coverage	20
12 Communications	20
13 Essential Supplies and Services	20
14 Review and Provision of Infrastructure.....	20
15 Infrastructure Maintenance, Rehabilitation, & Renewal	21
16 Sampling, Testing & Monitoring	22
17 Measurement and Recording Equipment Calibration and Maintenance	23
18 Emergency Management.....	23
19 Internal Audits.....	23
20 Management Review	23
21 Continual Improvement.....	23
22 Revision History.....	24

DWQMS Matrix

The DWQMS Matrix provided below indicates how the PLAN requirements of Ontario's DWQMS are addressed by Northern Waterworks Inc. DWQMS Elements are addressed through a combination of documentation which includes Operational Plans, corporate procedures and system-specific procedures. This matrix is intended to facilitate the understanding of the reader with respect to the structure of NWI's QMS. Additionally, this matrix will act to facilitate internal and external auditing processes.

DWQMS Element	Document Title
1 – Quality Management System	Operational Plan [SL-OP]
2 – QMS Policy	Operational Plan [SL-OP]
3 – Commitment and Endorsement	Operational Plan [SL-OP]
4 – QMS Representative	QMS Representative Policy [NWI-QMS-4]
5 – Document & Records Control	Document & Records Control Procedure [NWI-QMS-5]
6 – Drinking-Water System	Operational Plan [SL-OP]
7 – Risk Assessment	Risk Assessment Procedure [NWI-QMS-7]
8 – Risk Assessment Outcomes	Risk Assessment Outcomes – Sioux Lookout [SLDWS-QMS-8] Risk Assessment Outcomes – Hudson [HDWS-QMS-8]
9 – Organizational Structure, Roles, Responsibilities and Authorities	Organizational Structure, Roles, Responsibilities and Authorities [NWI-QMS-9]
10 – Competencies	Competencies Policy [NWI-QMS-10]
11 – Personnel Coverage	Personnel Coverage Policy [NWI-QMS-11]
12 – Communications	QMS Communication Procedure [NWI-QMS-12]
13 – Essential Supplies and Services	Essential Supplies and Services Procedure [NWI-QMS-13]
14 – Review and Provision of Infrastructure	Review and Provision of Infrastructure Procedure [NWI-QMS-14]

DWQMS Element	Document Title
15 – Infrastructure Maintenance, Rehabilitation and Renewal	Operational Plan [SL-OP]
16 – Sampling, Testing and Monitoring	Sampling, Testing and Monitoring Procedure – Sioux Lookout [SLDWS-QMS-16] Sampling, Testing and Monitoring Procedure – Hudson [HDWS-QMS-16]
17 – Measurement and Recording Equipment Calibration and Maintenance	Measurement and Recording Equipment Calibration and Maintenance Procedure [NWI-QMS-17]
18 – Emergency Management	Emergency Management Procedure [NWI-QMS-18]
19 – Internal Audits	Internal Audit Procedure [NWI-QMS-19]
20 – Management Review	Management Review Procedure [NWI-QMS-20]
21 – Continual Improvement	Continual Improvement Procedure [NWI-QMS-21]

1 Quality Management System

The Drinking Water Quality Management System (QMS) for the Sioux Lookout & Hudson Drinking Water Systems is documented in this Operational Plan as part of NWI's efforts to ensure that clean and safe drinking water is reliably supplied to all customers served by these systems. The development and continual improvement of the Operational Plan will help to ensure that all regulatory requirements are met and that consumers can be confident that their drinking water will be protected through the effective application of the QMS. This Operational Plan was developed to meet the Ministry's Drinking Water Quality Management Standard.



2 Quality Management System Policy

The Corporation of the Municipality of Sioux Lookout utilizes the services of Northern Waterworks Inc. (NWI), an independent contracted operating authority, to operate, maintain and manage the two (2) drinking water systems (as per agreement). The Municipality of Sioux Lookout and Northern Waterworks Inc. are committed to the following:

- 1) Providing the consumer with clean, safe drinking water.
- 2) Meeting or exceeding all applicable legislative and regulatory requirements; and,
- 3) Maintaining and continually improving our quality management system.

3 Commitment and Endorsement

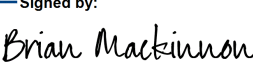
The Municipality of Sioux Lookout and Northern Waterworks Inc. (NWI) support the implementation, maintenance and continual improvement of a Quality Management System for the Sioux Lookout & Hudson Drinking Water Systems, as documented in this Operational Plan. The Municipality and NWI acknowledge the need for and support the provision of sufficient resources to maintain and continually improve the QMS. For the purposes of the QMS, the persons in the undersigned authorized positions shall represent the Municipality of Sioux Lookout as the system Owner and NWI as the accredited operating authority, respectively. The undersigned hereby endorse this Operational Plan:

Name & Title:	Signature:	Date:
Brian MacKinnon Chief Administrative Officer & Municipal Clerk The Municipality of Sioux Lookout	Signed by:  E0C310583FE8460...	16 August 2024 08:39 EDT
Robert Lariviere Chief Operating Officer Northern Waterworks Inc.	Signed by:  15ABA365FB3E472...	16 August 2024 05:47 PDT

Endorsement of the QMS shall be updated when there are changes to the Operational Plan (OP) document or the authorized representative positions. New signatures are not required when the person in an authorized signatory position changes

4 QMS Representative

Refer to the *QMS Representative Policy* [NWI-QMS-4].

5 Document & Records Control

Refer to the *Document and Records Control Procedure* [NWI-QMS-5].

6 Drinking-Water System

6.1 Sioux Lookout Drinking Water System

6.1.1 System Overview

The Sioux Lookout Drinking Water System provides a potable water supply to the community of Sioux Lookout and is composed of a raw water pumping station, the Sioux Lookout Water Treatment Plant (SLWTP, a Class III water treatment facility having an approved rated capacity of 5,200 m³/day), and the Sioux Lookout water distribution system (a Class II water distribution system which includes the Sioux Lookout Standpipe and the Curtis Street Booster Station). The Sioux Lookout DWS is owned by the Corporation of the Municipality of Sioux Lookout and Northern Waterworks Inc. serves as the accredited operating authority.

The source water for the treatment process is from a surface water source (Pelican Lake) located within the Municipality. Potential pathogenic organisms are removed from the raw water by coagulation, flocculation, membrane ultrafiltration, UV disinfection and free chlorine disinfection processes. This multiple barrier approach helps to ensure consistently safe and clean drinking water.

6.1.2 Source Water Characteristics and Event-Driven Fluctuations

General characteristics for the source water supply are provided in the table below.

Parameter ¹	Result Ranges (January 1, 2011 – October 31, 2022)
Turbidity (NTU)	0.23 – 1.53
UV Transmittance (%)	37.5 – 55.3
pH	7.1 – 7.8
Alkalinity (mg/L as CaCO ₃)	25 – 45
E. Coli (MPN/100mL)	<1 – 11
Total Coliforms (MPN/100mL)	<1 – 2420

1. Turbidity, UV transmittance, pH and alkalinity results are expressed as monthly averages.

Event-driven fluctuations in the source water and subsequent operational challenges are summarized as follows:

- (1) Seasonal changes in water temperature may impact treatment performance as it concerns membrane ultrafiltration and disinfection processes. Higher water temperatures are also associated with increased biological activity in the source water, resulting in higher turbidity, colour, micro-organism counts, and the potential for taste and odour problems.

Generally, seasonal changes pose only minor operational challenges, and these challenges can be anticipated and may require adjustments to treatment processes or chemical dosages.

- (2) Several potential pollution sources from nearby or upstream land use activities are known to affect Pelican Lake. The lake is influenced by recreational activities (boats, float planes) and commercial operations and fueling facilities line the shore. Proximal railway lines and roadways both upstream and downstream of the intake also present the potential for a chemical spill. Leachate from defective upstream private septic systems, effluent discharged from the municipal sewage treatment plant, and storm water discharges and surface runoff during heavy rainfall events could also impact source water quality. Pelican Lake is also susceptible to natural bacteriological contamination by wildlife.

Monitoring processes (e.g., routine or additional regulatory sampling and water quality testing, continuous monitoring), control measures (including normal treatment barriers) and contingency plans are available to minimize the operational challenges posed by a source water contamination event.

- (3) Algal blooms in the source water pose a potential concern, whereby such events could interfere with treatment processes and associated toxins may pose a risk of treated water contamination.

Monitoring processes, control measures and contingency plans are available to minimize the operational challenges posed by algal blooms.

- (4) Pelican Lake has in the past experienced elevated concentrations of *Cryptosporidium* and *Giardia*, necessitating both special monitoring and a potential increase in pathogen removal requirements.

Elevated *Cryptosporidium* and *Giardia* concentrations in source water no longer pose operational challenges following the installation and commissioning of UV disinfection equipment. The equipment was installed in anticipation of an increase in pathogen removal requirements.

Monitoring processes, control measures and response procedures are available to minimize UV system failure events.

6.1.3 Treatment Processes

6.1.3.1 Source Water Intake & Pumping

Source water is obtained from Pelican Lake, a large inland lake forming part of the English River drainage system. Raw water is drawn through a flared elbow intake structure equipped with a coarse screen located approximately 150 meters offshore. Water is then gravity fed through a 350 mm diameter intake pipe extending from the intake structure to a wet well with a storage volume of 188.1 m³ at the raw water pumping station. The station includes two static, vertical removable inlet screens and three vertical turbine low lift pumps for transferring source water through a transmission line to the Sioux Lookout Water Treatment Plant.

6.1.3.2 Coagulation and Flocculation

A coagulant chemical and a pre-treatment pH/alkalinity adjustment chemical are added to the incoming raw water at the Sioux Lookout WTP. Rapid mixing of the chemicals with the raw water occurs as the raw water passes through an in-line static mixer. Coagulated water then enters two in-line flocculation tanks, each having a volume of 24 m³ and equipped with a mechanical mixer. In the tanks water is gently mixed to promote floc formation, which will in turn facilitate membrane ultrafiltration.

Flocculated water is then directed through a 300 mm diameter pipe to the two underground process reservoirs containing submerged membrane ultrafilters. The flow of flocculated water is automatically regulated to maintain a constant level in the process reservoirs. Impurities in the water are removed by a combination of absorption onto the floc in the process reservoirs and by membrane ultrafiltration.

6.1.3.3 Membrane Ultrafiltration

The membrane filters at the Sioux Lookout Water Treatment Plant consist of 160 GE ZeeWeed 500D hollow-fiber membrane filter modules (20 modules per cassette, two cassettes per tank, two tanks per process reservoir). The membranes have a nominal pore size of 0.04 µm, ensuring that no particulate matter exceeding this size can enter the treated water stream.

The filter modules are immersed in flocculated water and operate under a low vacuum created within the hollow fibers by a permeate pump. If for any reason the flow to either membrane process reservoir is reduced and the liquid level drops too low, the permeate pump will stop to prevent the water level from dropping to a point where the membrane filter surface is exposed to the atmosphere. During production, water (permeate) is drawn through the membrane by the applied vacuum, effectively filtering impurities from the water. Permeate is then either used to fill the backpulse tanks or is directed to the UV reactors for disinfection.

The integrity of the membrane ultrafilters is monitored using a fully automated Membrane Integrity Test System (i.e., pressure decay tests) and turbidity analyzers connected to each of the two-process train permeate discharge lines. The results of pressure decay tests are also used to determine the pathogen log removal values achieved by the membrane ultrafilters.

6.1.3.3.1 Aeration

Air flow is introduced at the bottom of the membrane modules to create a turbulence which scrubs and cleans the outside of the membrane fibres, allowing them to operate at a high flux rate. The air also has the beneficial side effect of oxidizing iron and organic compounds. The air blowing system at the Sioux Lookout WTP consists of three blowers.

6.1.3.3.2 Reject Wastewater

The solids that accumulate in the process reservoirs are removed by submersible pumps in the bottom of each tank at a rate typically between 10 to 20% of daily raw water flow. To maintain the desired reject water ratio, the reject flow is measured by a flow meter and is regulated according to the raw water flow to the tank. The ratio of reject water to treated water can be varied if desired by using the PLC system to suit raw water conditions. Reject wastewater is directed to the waste sump.

6.1.3.3.3 Air Extraction

Due to the low operating pressure of the system and the pressure differential across the membrane, there is a tendency for dissolved air to be released from the water. To prevent problems associated with air locks in the piping and pumps (which may cause the permeate pump to lose its prime), an air extraction system is incorporated into the process.

The air removal system consists of two 360 L air separation vessels and two air removal vacuum pumps. Permeate flows into the vessel and any air released from the water collects at the top and is automatically removed from the system by a vacuum pump that runs continuously. If all the air is removed from the vessel, a priming valve closes automatically to prevent water entering the vacuum pump.

6.1.3.3.4 Backpulsing

Backpulsing is a method of membrane filter cleaning and is achieved by reversing the flow of water through the membranes at low pressure. The water used for the backpulse is permeate that has been collected in two storage tanks.

Flow is backpulsed using the variable speed permeate pumps. The frequency and duration of backpulses vary, but an example of a typical configuration is one backpulse occurring every 15 to 30 minutes for a duration of 15 to 30 seconds.

The backpulse water storage tanks are equipped with level sensors and are filled automatically with permeate during normal plant operation. When the level in the storage tank is low, permeate is diverted into the storage tank. When the tank is filled, flow is automatically diverted back to the permeate discharge.

6.1.3.3.5 Filter Cleans

The flow through the membranes is monitored, as is the vacuum pressure applied to the membranes. As the water is drawn through the membranes during filtration, solids accumulate on the membrane surface. As the solids accumulate, they restrict the flow through the membranes and eventually membrane cleaning is required to maintain the filtered water flow rate. This will be noticed by an increase of vacuum used to pull the permeate water through the filters.

There are two types of cleanings used in Sioux Lookout: citric acid for inorganic fouling and sodium hypochlorite for organic fouling. Most of the cleanings are a citric acid type with a sodium hypochlorite cleaning when the fibers become fouled with organics.

The Sioux Lookout WTP includes one (1) 1,890 L clean-in-place tank used for mixing citric acid solutions for membrane cleaning purposes. The tank is filled using the domestic water supply and it includes a pump and piping system for reversing the flow of water through the membranes during a chemical clean.

6.1.3.4 Disinfection

Disinfection occurs following membrane filtration, upstream from the chlorine contact chamber and treated water storage reservoir. Filtrate is passed through one of two available UV reactors in a duty/standby configuration, each unit rated at 65 L/s and including a UV intensity sensor and shut-off controls. UV disinfection ensures that any potentially pathogenic organisms that remain after previous treatment processes are destroyed or inactivated. Consistent disinfection is ensured by the continuous monitoring of UV disinfection parameters.

Sodium hypochlorite solution is applied to the filtrate after it passes through the UV reactors upstream from the chlorine contact chamber. At the Sioux Lookout WTP, sodium hypochlorite addition is used to achieve both primary and secondary disinfection requirements. Concerning primary disinfection, free chlorine disinfection is necessary to meet log inactivation credits for viruses.

Secondary disinfection requirements are achieved by adding enough chlorine at the water treatment plant to maintain a free chlorine residual throughout the distribution system. The purpose of this procedure is to prevent the growth of biofilm within the distribution system and to protect the water from re-contamination as it flows through the community.

6.1.3.5 Fluoridation & pH Adjustment

Following filtration and UV disinfection, fluorosilicic acid is added to permeate upstream from the chlorine contact chamber to reduce tooth decay in the community. The coagulant used at the Sioux Lookout WTP also reduces the pH of the water, and a pH/alkalinity adjustment chemical is added to the permeate prior to UV disinfection. Increasing the pH of finished water at the facility helps to prevent corrosion in the water distribution system.

6.1.3.6 Treated Water Storage and Delivery

Following disinfection, filtrate is directed to the two celled interconnected in-ground chlorine contact chamber, each cell with a contact volume of 94.3 m³. The chlorine contact chamber uses a baffling system to allow disinfectant to mix adequately with the water. Water then overflows the contact chamber and is directed to the treated water reservoir, a two-celled interconnected in-ground reservoir with a total storage volume of 252 m³. From the reservoir water enters the high lift pumping chamber with a storage volume of 51 m³. A total of three (3) variable speed vertical turbine high lift pumps are available to transfer finished water from the pumping chamber to the water distribution system.

6.1.3.7 Instrumentation & Emergency Power

The Sioux Lookout WTP includes programmable logic controllers complete with a SCADA system for process monitoring and control. Critical process instruments include one raw water flow measuring device, two filtrate turbidity analyzers, two filtrate flow measuring devices, two UV intensity sensors, one treated water flow measuring device, one treated water turbidity analyzer, one treated water fluoride residual analyzer, and one treated water free chlorine residual analyzer.

The system also includes a 300-kW standby diesel generator for supplying emergency power to both the raw water pumping station and the water treatment facility.

6.1.3.8 Process Waste Residuals Management

All process wastewater at the Sioux Lookout WTP is discharged to a waste sump with a storage volume of 32.7 m³ and including two waste sump pumps for transferring wastewater directly to the sanitary sewer system. Process wastewater inputs include the reject wastewater and filter-to-waste wastewater

produced during the primary ultrafiltration process, drains and overflows from the backpulse tanks and wash tank, and discharge from the vacuum pumps.

6.1.4 Distribution System Components

The Sioux Lookout water distribution system consists of approximately 34 km of watermains, 250 water main gate valves, 172 hydrants, a community standpipe and a booster station. The Sioux Lookout standpipe has a useable volume of 1,400 m³ and serves to regulate system pressure and to provide extra water storage. The standpipe water level regulates the transfer of water from the treated water storage reservoir at the Sioux Lookout WTP. The Curtis Street Booster Station increases water pressure in the northeast portion of the distribution system and includes two variable speed centrifugal pumps.

6.1.5 Process Flow Diagram

A process flow diagram for the system is provided on the following page.

Sioux Lookout Water Treatment Plant

PROCESS FLOW DIAGRAM

LEGEND

NOTE: THIS SCHEMATIC DOES NOT INCLUDE VALVE SYSTEMS NOR DOES IT INCLUDE DETAILED INFORMATION CONCERNING CHEMICAL FEED SYSTEMS.

	PROCESS LINES (RAW, PERMEATE, TREATED)		LOW LIFT PUMP		VACUUM PUMP		FLOW MEASURING DEVICE
	WASTE/RECYCLE LINES		HIGH LIFT PUMP		REJECT PUMP		TURBIDITY ANALYZER
	BACKPULSE/BACKWASH LINES		PERMEATE PUMP		WASTE PUMP		CHLORINE RESIDUAL ANALYZER
	DISTRIBUTION WATER		BACKWASH PUMP		pH ANALYZER		FLUORIDE RESIDUAL ANALYZER
	CHEMICAL LINES						
	PROCESS AIR						
	OTHER LINES						

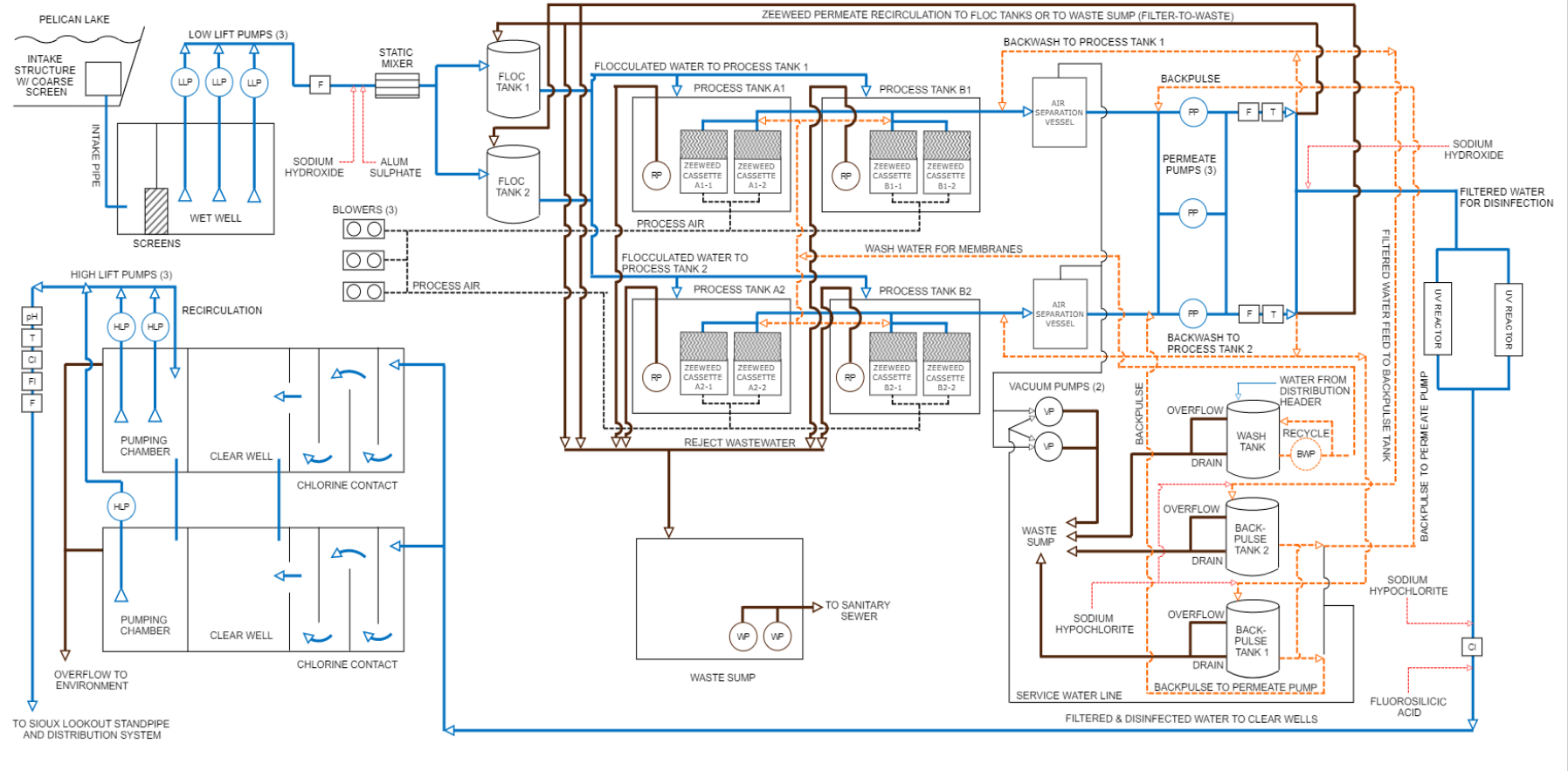

Revision Date: 13 August 2024
 Revision Level: 7
 Internal Reference: SL-OP
 Page 13 of 25



6.2 Hudson Drinking Water System

6.2.1 System Overview

The Hudson Drinking Water System provides a potable water supply to the community of Hudson and is composed of a raw water pumping station, the Hudson Water Treatment Plant (HWTP, a Class II water treatment facility having an approved rated capacity of 726 m³/day) and the Hudson water distribution system (a Class I water distribution system). The Hudson Drinking Water System is owned by the Corporation of the Municipality of Sioux Lookout and Northern Waterworks Inc. serves as the accredited operating authority.

The source water for the treatment process is drawn from a surface water source (Lost Lake) located within the Municipality. Potential pathogenic organisms are removed from the raw water by coagulation, flocculation, clarification, filtration, and UV (primary) and free chlorine (secondary) disinfection processes. This multiple barrier approach helps to ensure consistently safe and clean drinking water.

6.2.2 Source Water Characteristics and Event-Driven Fluctuations

General characteristics for the source water supply are provided in the table below.

Parameter ¹	Result Ranges (January 1, 2011 – October 31, 2022)
Turbidity (NTU)	0.25 – 2.97
UV Transmittance (%)	63.3 – 69.9
pH	7.1 – 8.2
Alkalinity (mg/L as CaCO ₃)	34 – 55
E. Coli (MPN/100mL)	<1 – 16
Total Coliforms (MPN/100mL)	<1 – >2420

1. Turbidity, UV transmittance, pH, and alkalinity results are expressed as monthly averages.

Event-driven fluctuations in the source water and subsequent operational challenges are summarized as follows:

- (1) Seasonal changes in water temperature may impact treatment performance as it concerns chemically assisted filtration and disinfection processes. Higher water temperatures are also associated with increased biological activity in the source water, resulting in higher turbidity, colour, micro-organism counts, and the potential for taste and odour problems.

Generally, seasonal changes pose only minor operational challenges, and these challenges can be anticipated and may require adjustments to treatment processes or chemical dosages.

- (2) Potential pollution sources are known to affect Lost Lake. The lake is influenced by recreational activities (boats, float planes), and commercial houseboat operators and fuel storage tanks line the shore of the lake near the water treatment facility. The raw water pumping station and water treatment plant are also situated adjacent to a railway, which presents the potential for derailment and a chemical spill. Hudson does not have a municipal sanitary sewer and treatment system, and leachate from defective private septic systems represents a source of contamination. Finally, Lost Lake is susceptible to natural bacteriological contamination by wildlife.

Monitoring processes (e.g., routine or additional regulatory sampling and water quality testing, continuous monitoring), control measures (including normal treatment barriers) and contingency plans are available to minimize the operational challenges posed by a source water contamination event.

- (3) Algal blooms in the source water pose a potential concern, whereby such events could interfere with treatment processes and associated toxins may pose a risk of treated water contamination.

Monitoring processes, control measures and contingency plans are available to minimize the operational challenges posed by algal blooms.

6.2.3 Treatment Processes

6.2.3.1 Source Water Intake & Pumping

Source water is obtained from Lost Lake, a large inland lake forming part of the English River drainage system. Raw water is drawn through a flared elbow intake inside a cribbed structure located approximately 43 meters offshore at a depth of 9.5 meters. Water is then gravity fed through a 150 mm diameter intake pipe extending from the intake structure to a wet well with a storage volume of 111.6 m³ at the raw water pumping station. Three vertical turbine low lift pumps located at the station are available to transfer source water through a transmission line to the Hudson Water Treatment Plant.

6.2.3.2 Coagulation, Flocculation and Sedimentation

A coagulant chemical is added to the incoming raw water prior to the water entering two package treatment units. Rapid mixing of the coagulant chemical with the raw water occurs as the raw water passes through an in-line static mixer. Each package treatment unit is rated at 4.2 L/s and includes a three-stage flocculator, a clarifier, and a dual media filter. In the three-stage flocculator, coagulated water is gently mixed to promote the formation of floc masses. The optional application of a coagulant aid at the stage of treatment is intended to form larger floc aggregates. Process water then enters the clarifier, where its velocity is reduced to allow for the separation and settling of floc. Supernatant

overflows into the clarifier effluent launders and is directed to the dual media filter.

6.2.3.3 Filtration

Most of the particulate matter that was present in the raw water will become an insoluble floc and be removed in the clarifiers. During normal operation, however, some floc passes from the clarifiers to the filters. The filters remove any remaining particles that have not settled out by passing the water through layers of anthracite and silica sand, supported by a layer of coarse gravel. Filtrate is directed through an underdrain system and to the UV reactors for disinfection.

The filters are periodically cleaned by using an air scour to agitate the entire media bed and reversing the flow of water (backwashing) through the filter using dedicated pumps. After the backwash process, filtered water is directed to the backwash equalization chamber (i.e., rinsing-to-waste) until a pre-determined amount of time has passed and the water meets specific water quality objectives.

6.2.3.4 Disinfection

Disinfection occurs following filtration, immediately upstream from the treated water storage reservoir. Filtrate is passed through one of two available UV reactors, each unit rated at 8.4 L/s and including a UV intensity sensor and shut-off controls. UV disinfection ensures that any potentially pathogenic organisms that remain after previous treatment processes are destroyed or inactivated. Consistent disinfection is ensured by the continuous monitoring of UV disinfection parameters.

A super-chlorinated solution is applied to the filtrate after it passes through the UV reactors upstream from the treated water storage reservoir. Secondary disinfection requirements are achieved by adding enough chlorine at the water treatment plant to maintain a free chlorine residual throughout the water distribution system. The purpose of this procedure is to prevent the growth of biofilm within the distribution system and to protect the water from re-contamination as it flows through the community.

6.2.3.5 pH Adjustment

The coagulant used at the Hudson WTP reduces the pH of the water, and a pH/alkalinity adjustment chemical (sodium hydroxide) is added to the filtrate as it is directed to the treated water storage reservoir. The Hudson Drinking Water System also adheres to a *Corrosion Control Plan* to control lead release in residential and non-residential plumbing, and the use of a pH/alkalinity adjustment chemical is required to ensure that finished water pH is consistently maintained between 7.6 and 8.0.

6.2.3.6 Treated Water Storage and Delivery

Following disinfection filtrate is directed to the two-celled storage reservoir with a total storage volume of 564 m³. Treated water is delivered from the reservoir to the distribution system using two variable speed vertical turbine high lift pumps located at the WTP. An optional chlorine injection point exists for trim chlorination purposes at a location downstream from the reservoir but prior to entry to the distribution system.

6.2.3.7 Emergency Power and Instrumentation

The Hudson WTP includes a PLC complete with a SCADA system for process monitoring and control. Critical process instruments include two raw water flow measuring devices, two filtrate turbidity analyzers, two UV intensity sensors, one treated water flow measuring device, one treated water turbidity analyzer, and two treated water free chlorine residual analyzers (located on either side of the optional trim chlorine injection point).

The system also includes a 150-kW standby diesel generator located at the raw water pumping for supplying emergency power to both the pumping station and the water treatment facility.

6.2.3.8 Process Waste Residuals Management

Clarifier sludge discharge, backwash wastewater and rinse-to-waste water are directed to the backwash equalization chamber at the Hudson WTP. Process wastewater then flows to a concrete sludge/sedimentation chamber with a total capacity of 22,700 L located external to the treatment plant building. Sludge is allowed to settle in the chamber and supernatant is directed to a subsurface disposal system consisting of a proprietary storm water type chamber-based storage and exfiltration field with a total storage capacity of approximately 100 m³. Accumulated sludge in the sludge/sedimentation chamber is periodically removed using a vacuum truck.

6.2.4 *Distribution System Components*

The Hudson water distribution system was installed exclusively in 1990 and includes approximately 6 km of water mains, 46 water main gate valves, and 7 hydrants. Watermain materials consist of HDPE and PVC, ranging in size from 50 to 150 mm in diameter.

6.2.5 *Process Flow Diagram*

A process flow diagram for the system is provided on the following page.

Hudson Drinking Water System Process Flow Diagram

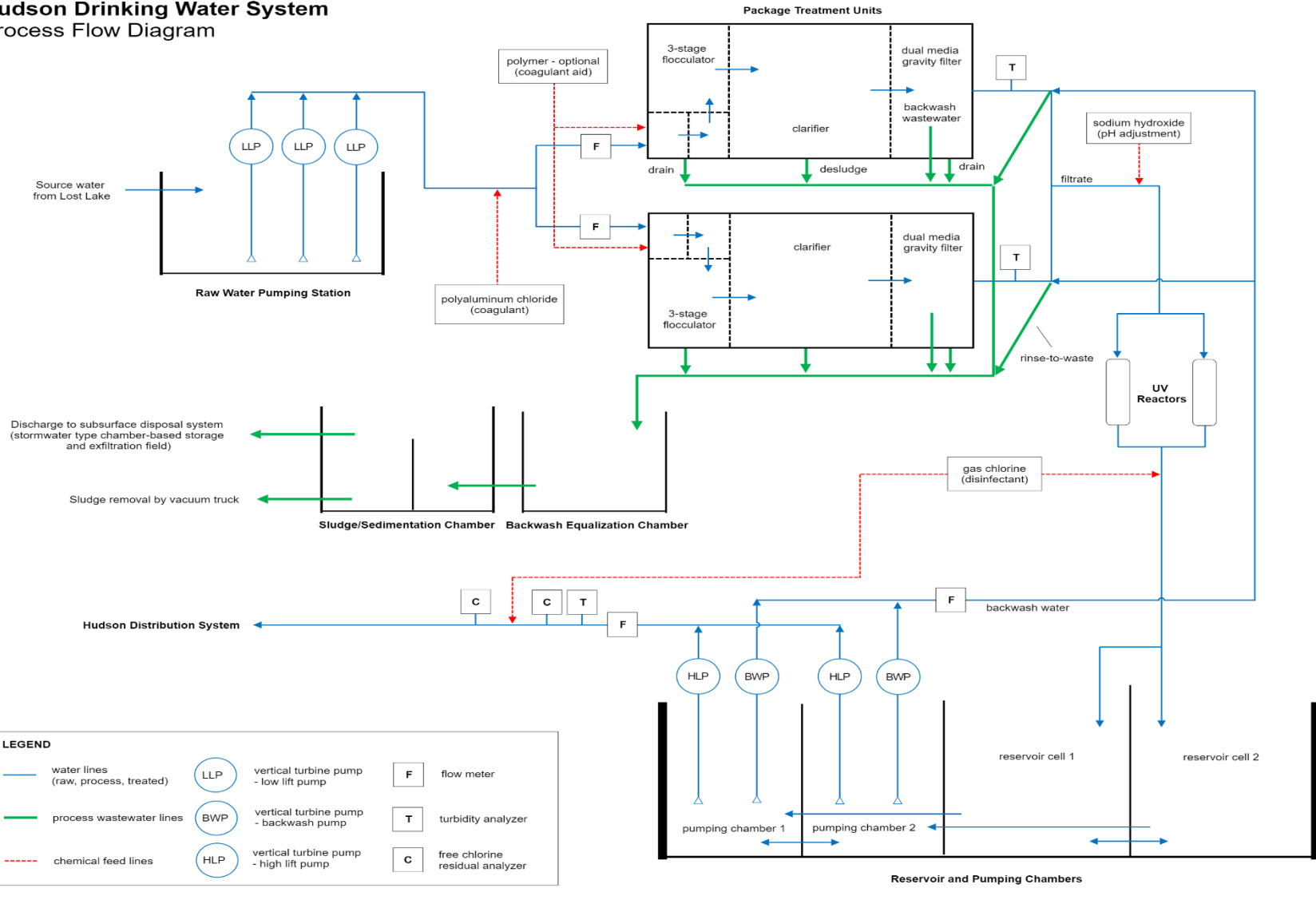

Revision Date: 13 August 2024
 Revision Level: 7
 Internal Reference: SL-OP
 Page 18 of 25



7 Risk Assessment

Refer to the *Risk Assessment Procedure* [NWI-QMS-7].

8 Risk Assessment Outcomes

8.1 Interpretation of the Risk Assessment Outcomes

The risk assessment outcomes were developed using the *Risk Assessment Procedure* [NWI-QMS-7]. This procedure contains all the information necessary to interpret the *Risk Assessment Outcomes* for the respective drinking water systems. The risk assessment outcomes include the following:

- (1) Potential hazardous events and associated hazards.
- (2) Assessed risks associated with the occurrence of hazardous events, including considering the likelihood, severity and detectability of the event.
- (3) Ranked hazardous events.
- (4) Monitoring processes and control measures associated with each hazardous event.
- (5) Critical control points and their respective critical control limits; and,
- (6) Response procedures for hazardous events.

8.2 Monitoring Critical Control Limits

Various monitoring processes are in place to monitor critical control limits and to identify deviations from those limits. Critical control limits and other parameters associated with critical control limits are monitored by the following processes:

- (1) Continuous monitoring and alarm systems (e.g., analyzers and trending associated with free chlorine residual data, flow, pressure, etc.). Alarm systems notify operators when critical control limits or other alarm set points have been breached.
- (2) Routine regulatory sampling (e.g., weekly microbiological analyses, quarterly chemical analyses, etc.).
- (3) Routine water quality testing (e.g., daily tests for free chlorine, turbidity and pH, etc.).
- (4) Operational checks, where operators collect and interpret data (e.g., pump operating hours, flows, analyzer readings, compliance data, etc.) and inspect facilities daily.
- (5) Additional operational checks associated with planned maintenance, where certified operators conduct more detailed monthly inspections of facilities and,

- (6) Notification from external parties (e.g., notification that a chemical contamination event has occurred, notification of a large fire in the community, a water quality complaint that results in the identification of a cross-connection, etc.).

8.3 Critical Control Limit Deviations

Procedures outlining how to respond to, report and record deviations from critical control limits exist as a series of *Emergency Response Procedures* (contingency plans). Specifically, *Emergency Response Procedures* contain step-by-step response instructions, including instructions related to communication protocols and recordkeeping requirements.

All critical control limit deviations are recorded in the facility logbook but may also be recorded within Adverse Water Quality Incident documentation, call-out records, customer complaint records and operational spreadsheets.

9 Organizational Structure, Roles, Responsibilities and Authorities

Refer to the *Organizational Structure, Roles, Responsibilities & Authorities Policy* [NWI-QMS-9].

10 Competencies

Refer to the *Competencies Policy* [NWI-QMS-10].

11 Personnel Coverage

Refer to the *Personnel Coverage Policy* [NWI-QMS-11].

12 Communications

Refer to the *QMS Communication Procedure* [NWI-QMS-12].

13 Essential Supplies and Services

Refer to the *Essential Supplies and Services Procedure* [NWI-QMS-13].

14 Review and Provision of Infrastructure

Refer to the *Review and Provision of Infrastructure Procedure* [NWI-QMS-14].

15 Infrastructure Maintenance, Rehabilitation, & Renewal

15.1 Planned Maintenance, Rehabilitation, & Renewal

NWI, under contract with the owner, maintains a program of scheduled inspection and maintenance of infrastructure for which it is operationally responsible. Maintenance activities are developed according to manufacturer instructions, regulatory requirements, industry standards and/or client service requirements. Records of planned maintenance activities are controlled in accordance with NWI's *Document and Records Control Procedure* [NWI-QMS-5]. The major components of the infrastructure maintenance, rehabilitation and renewal programs in place for the respective drinking water systems are described below.

- (1) The *Planned Maintenance Activities* Standard Operating Procedure documents a comprehensive program that is conducted by operations staff on a monthly or less frequent basis. This procedure dictates planned inspection and maintenance activities associated with infrastructure components including pumps, valves, chemical feed systems, treatment equipment, emergency response equipment, standby power systems, heating systems, lighting and other components necessary to ensure a reliable supply of safe drinking-water.

This procedure also facilitates infrastructure rehabilitation and renewal, as it requires the identification and reporting of deficiencies. Identified deficiencies may be addressed through operational budgets, particularly as it concerns the rehabilitation and renewal of smaller infrastructure components.

- (2) The *Measurement and Recording Equipment Calibration and Maintenance Procedure* documents certain planned calibration and maintenance activities that are specific to instrumentation. The associated *Calibration and Maintenance Records* are used to indicate a variety of maintenance activities, such as instrument inspection, cleaning and quality assurance. Generally, such activities are carried out by operations staff on a monthly basis.
- (3) At the Sioux Lookout WTP, additional maintenance is performed on the membrane filtration units depending upon various operational indicators and in accordance with established Standard Operating Procedures. Such maintenance tasks include performing manual backwashes, recovery cleans and repairs. Membrane filter cleans utilizing sodium hypochlorite are typically conducted to remove organic buildup. Citric acid cleans are conducted as required based upon transmembrane pressure results. These cleans are designed to removed inorganic buildup.
- (4) The water distribution systems are flushed, and hydrants are operated and inspected on an annual basis. Major distribution system and hydrant deficiencies identified during this program are used to plan for future maintenance activities.
- (5) NWI monitors and coordinates additional maintenance activities that include infrastructure inspection, maintenance or servicing that occur on a recurring but less frequent basis. Examples of such activities include flow meter calibration verification, backflow prevention device testing, reservoir cleaning and inspections, thermal

imaging inspections, emergency generator servicing and load testing, the replacement of various critical components, etc.

- (6) The annual infrastructure review and budgeting processes are the main methods through which infrastructure rehabilitation and renewal occurs. Specifically, the outcomes of the infrastructure review represent the main inputs into annual capital expenditure budgets prepared by NWI for consideration and approval by the Municipality of Sioux Lookout. The integration of annual budgeting and infrastructure review processes represents a continuous and cohesive effort to identify deficiencies and plan for infrastructure rehabilitation and renewal.

15.2 Unplanned Maintenance

Unplanned maintenance tasks related to drinking water system treatment components result from equipment or infrastructure failures. Unplanned maintenance is authorized by the Operations Manager or the Overall Responsible Operator. Documentation of these unplanned maintenance tasks are recorded in the facility logbooks. Measures to prepare for and expedite unplanned maintenance tasks in these scenarios include equipment interchangeability and redundancy, spare parts inventories, and the availability of relevant operations and maintenance manuals.

Unplanned maintenance tasks, infrastructure repair and renewal related to distribution system components are typically performed by the Municipality of Sioux Lookout, in conjunction with representation from Northern Waterworks Inc. Measures to prepare for and expedite unplanned maintenance tasks include the cataloguing of the distribution system, maintaining a parts inventory, and having access to repair procedures.

15.3 Program Monitoring

To ensure that the planned maintenance program remains effective, the *Planned Maintenance Activities SOP* and the *Measurement and Recording Equipment Calibration and Maintenance Procedure* are reviewed and updated annually. This review is facilitated by Compliance and includes Operations Managers and Operators. The review accounts for changes to infrastructure and allows an opportunity to refine and continually improve the maintenance program, particularly as it involves incorporating new best practices.

15.4 Program Communication

NWI's infrastructure maintenance, rehabilitation and renewal programs are communicated to the Municipality of Sioux Lookout on annual basis as a component of the communication of management review results. Significant planned and unplanned infrastructure maintenance, rehabilitation and renewal activities are also described in monthly operational reports submitted to the Municipality.

16 Sampling, Testing & Monitoring

Refer to the *Sampling, Testing, & Monitoring Procedures* for the Sioux Lookout Drinking Water System [SLDWS-QMS-16] and the Hudson Drinking Water System [HDWS-QMS-16].

17 Measurement and Recording Equipment Calibration and Maintenance

Refer to the *Measurement and Recording Equipment Calibration and Maintenance Procedure* [NWI-QMS-17].

18 Emergency Management

Refer to the *Emergency Management Procedure* [NWI-QMS-18].

19 Internal Audits

Refer to the *Internal Audit Procedure* [NWI-QMS-19].

20 Management Review

Refer to the *Management Review Procedure* [NWI-QMS-20].

21 Continual Improvement

Northern Waterworks Inc. is committed to continually improving the effectiveness of its Quality Management System. Continual improvement is facilitated by the management review and internal auditing processes, which include the identification of QMS deficiencies and the assignment of preventive and corrective actions.

Refer to the *Continual Improvement Procedure* [NWI-QMS-21].

22 Revision History

Date	Revision	Comments
1-Mar-2011	1	Initial publication of Operational Plan.
24-Aug-2012	2	Publication of new version of Operational Plan following QMS re-structuring.
28-Oct-2013	3	Section 3 (Commitment and Endorsement) was amended to include the appropriate municipal representative and NWI's Top Management with respect to the Standard. Minor formatting changes were applied to the cover page, footers, and tables.
14-Jan-2014	4	Section 15 (Infrastructure Maintenance, Rehabilitation, and Renewal) was amended to clarify infrastructure maintenance, rehabilitation, and renewal programs for the subject system.
1-Mar-2017	5	Updates to sections 2 (QMS Policy), 3 (Commitment and Endorsement), 6 (DWS Description) and 15 (Infrastructure Maintenance, Rehabilitation and Renewal); section 13 (Essential Supplies and Services) removed following replacement with corporate procedure; formatting changes to entire document.
3-Nov-2022	6	Updates to incorporate both systems into a multi-system Operational Plan. Updates to sections 3 (Commitment and Endorsement), 6 (Drinking-Water System), 8 (Risk Assessment Outcomes) & 15 (Infrastructure Maintenance, Rehabilitation, and Renewal).
9 – Aug-2024	7	Updated to include new NWI Chief Operating Officer, Update to section 3 (Commitment and Endorsement)

**Schedule C – Director’s Directions for Operational Plans
(Subject System Description Form)
Municipal Residential Drinking Water System**

Fields marked with an asterisk (*) are mandatory.

Owner of Municipal Residential Drinking Water System *
The Corporation of the Municipality of Sioux Lookout

Subject Systems

Name of Drinking Water System (DWS) *	Licence Number *	Name of Operating Subsystems (if applicable)	Name of Operating Authority *	DWS Number(s) *
1. Sioux Lookout Drinking Water System	236-102		Northern Waterworks Inc.	220001405
2. Hudson Drinking Water System	236-101		Northern Waterworks Inc.	220005385

Contact Information for Questions Regarding the Operational Plan

Primary Contact

Last Name * Happl	First Name * Jessica	Middle Initial
Title * Manager QMS & Compliance	Telephone Number * 705-989-2045 ext.	Email Address * jessica.happl@ssmpuc.com

Secondary Contact

Last Name Lariviere	First Name Robert	Middle Initial
Title Chief Operating Officer	Telephone Number 807-728-0588 ext.	Email Address robert.lariviere@nwi.ca